

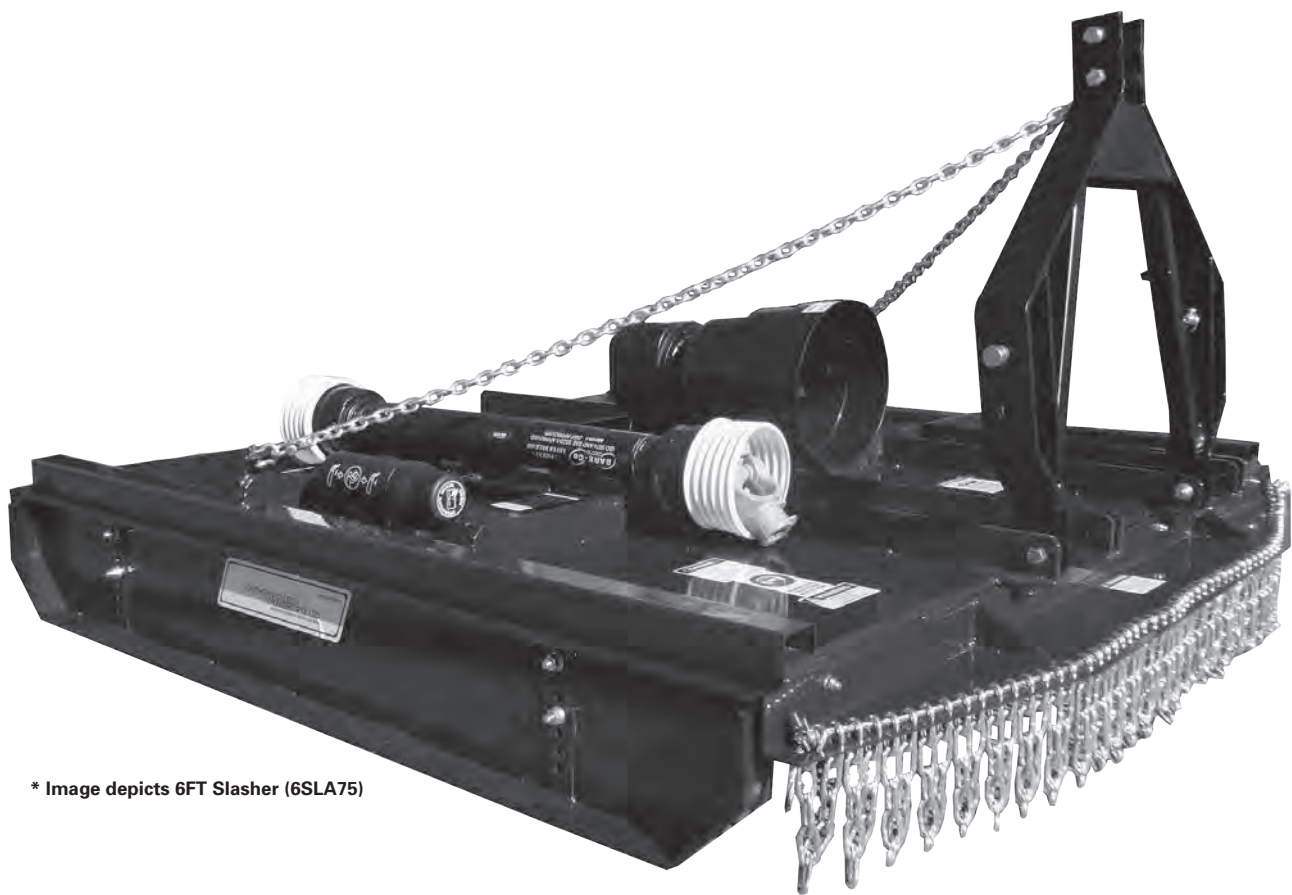

OPERATOR, MAINTENANCE & PARTS MANUAL

Rear Mount Slasher

4SLA45, 5SLA45, 5SLA75 & 6SLA75



* Image depicts 6FT Slasher (6SLA75)

1/29 MUSTANG DRIVE, RUTHERFORD NSW 2320
PO BOX 454, RUTHERFORD NSW 2320
T. 61 2 4932 3011 / F. 61 2 4932 1088
INFO@SXM.COM.AU / WWW.SXM.COM.AU

SOUTHERN CROSS MOWERS PTY LTD
T/A SOUTHERN CROSS AG MACHINERY
ABN 54 062 931 775



TABLE OF CONTENTS

Introduction.....	01
Safety	
• Safety Instructions.....	02
• General Safety Guidelines.....	03
• Employer / Controller Responsibilities.....	04
• Supervision, Instruction and Training.....	04
• Inspection, Maintenance and Repair.....	04
• Service and Maintenance Safety.....	04
• Start-Up Safety.....	05
• Operation.....	05
• Operation Safety.....	05
• Personal Protective Equipment (PPE).....	05
• Storage and Transport.....	05
• Storage Safety.....	05
• Transport Safety.....	05
• Modifications.....	06
• Safety Signs.....	06
• Installation of Safety Signs.....	06
Assembly Instructions (Step 1-7).....	07
• Step 8 PTO Shaft First Fitting.....	10
Prior to Operation.....	11
Preparation	12
Starting and Stopping Safety.....	12
Transportation Safety.....	14
Attaching to Tractor.....	15
Operating Instructions.....	15
Preoperational Adjustments.....	15
Maintenance Safety.....	16
Storage Safety.....	16
Safety Decal Locations.....	17
Slasher Safety Decals.....	18
Maintenance Schedule.....	20
Troubleshooting Guide.....	21
For Further Information.....	24
Slasher Parts Diagram.....	25
Slasher Parts List.....	26
Warranty & Register Your Warranty.....	28
Warranty Process.....	29

Manufacturers statement: Due to continuing improvements Southern Cross Ag Machinery Pty Ltd reserves the right to modify machinery design and specifications provided herein without any preliminary notice. Information provided herein is of descriptive nature.

**WARNING**

READ THE OPERATOR, MAINTENANCE AND PARTS MANUAL BEFORE USING THE SLASHER.

INTRODUCTION

Southern Cross Ag Machinery Slashers are available in 4ft (45HP), 5ft (45HP), 5ft (75HP) and 6ft (75HP).

This manual contains valuable information about your new Slasher. It has been carefully prepared to give you helpful suggestions for operating, adjusting and servicing your Slasher. Keep this manual handy for frequent reference. All new operators or owners must review the manual before using the equipment and at least annually thereafter.

It is the owner's and/or operator's responsibility to;

- Read and understand the information contained in this manual.
- Operate, lubricate, assemble and maintain the equipment in accordance with all instructions and safety procedures in this manual.
- Inspect the equipment and replace or repair any parts that are damaged or worn which could cause damage, wear to other parts, or cause a safety hazard.

Please contact your Southern Cross Ag Machinery Dealer if you need any further assistance with your Slasher or additional copies of the manual. Visit our website www.sxm.com.au for a complete list of dealers in your area. You can also download additional copies of this manual from our website.

SAFETY

Safety Instructions

Southern Cross Ag Machinery encourages good safety practices. Good safety practices not only protect you but also the people around you. Please ensure that everyone using this equipment is familiar with the recommended operating and maintenance procedures, has read and understood the Operators Manual and follows all the safety precautions. Most accidents can be prevented. Do not risk serious injury or death by ignoring good safety practices.

The alert symbol is used throughout this manual and on the product safety decals. This symbol indicates attention is required and identifies hazards concerning your personal safety and the safety of others. Please follow the recommended precautions.



The safety alert symbol means...
ATTENTION! BECOME ALERT! YOUR SAFETY IS INVOLVED!



CAUTION

The Caution Symbol indicates a potentially hazardous situation that, if not avoided, may result in minor or moderate injury. It may also be used to alert against unsafe practices.



WARNING

The Warning Symbol indicates a potentially hazardous situation that, if not avoided, could result in death or serious injury and includes hazards that are exposed when guards are removed. It may also be used to alert against unsafe practices.



DANGER

The Danger Symbol indicates an imminently hazardous situation that, if not avoided will result in death or serious injury. This signal word is to be limited to the most extreme situations, typically for machine components that, for functional purposes, cannot be guarded.

SAFETY continued

General Safety Guidelines

- Have a first-aid kit available for use and know how to use it.
- Have a fire extinguisher available, stored in a highly visible location and know how to use it.
- Wear appropriate protective gear. This list may include but is not limited to:
 - hard hat
 - protective shoes with slip resistant soles and steel caps
 - protective glasses or goggles
 - heavy gloves
 - wet weather gear
 - hearing protection
 - respirator or filter mask
- Read and understand the Operator's Manual and all safety decals before operating, servicing, adjusting, repairing or hitching the equipment.
- Do not attempt any unauthorised modifications to your Southern Cross Ag Machinery product as this could affect function or safety and could affect the life of the equipment.
- Never start or operate the Slasher except from the operator's station on the power unit.
- Inspect and clean the working area before operating. Remove all obstructions such as rocks, stumps and wire.
- Keep hands, feet, clothing, and hair away from moving parts.
- Ensure bystanders are clear of the area before operating. A minimum distance of 100 metres should be kept from all bystanders when Slasher is in operation.
- Never operate this equipment while using alcoholic beverages or drugs that can hinder alertness or coordination. Consult your doctor about operating this machine while taking any medication.
- Under no circumstances should children under the age of 18 be allowed to work with or around this equipment. Do not allow anyone to operate or assemble this equipment until they have read and understood this manual.
- This equipment is dangerous to anyone unfamiliar with its operation. The operator should be responsible, properly qualified and physically able person familiar with farm machinery and competent in this equipment's operation.
- All new operators or owners must review the manual before using the equipment and at least annually thereafter.
- In order to provide a clear view, certain illustrations in this manual may show an assembly with a safety guard removed equipment should never be operated in this condition. Keep all guards in place. If guard removal becomes necessary for repairs, reinstall the guards prior to use.
- Replace any safety decal that is not legible or is missing. The locations of such safety decals are indicated in this manual.
- Never exceed the limits of a piece of machinery. If its ability to do a job, or to do so safely, is in question – DON'T TRY IT.
- In addition to the design of this implement, safety decals and safety equipment, accident prevention is dependent upon the awareness, common sense, forethoughts, and proper training of everyone involved in the operation, transport, maintenance and storage of the machine. Also refer to safety messages and operating instructions in each of the appropriate sections of the tractor manual. Pay close attention to the safety decals affixed to the tractor and the Slasher.

SAFETY continued

Employer/Controller Responsibilities

OH&S legislation places obligations on the employer, or the controller of the Slasher, to identify the hazards and control the risks associated with the use of the Slasher in their workplace and to do so in accordance with the manufacturer's instructions.

When purchasing a Slasher:

- Ensure the manufacturer's instructions are provided at the point of purchase.
- Ensure the Slasher conforms to industry safety standards.
- Discuss your needs with the supplier, to ensure the Slasher is compatible with the power of your tractor and is appropriate for the intended application – consider the speed of your tractor's PTO and its compatibility with the Slasher's gearbox.
- Seek practical advice and instruction from the supplier on the use and limitations of the Slasher. If you are hiring, leasing or borrowing a Slasher on a temporary basis, get safe use instructions from the person supplying it.
- The employer must provide safety instructions to all those involved in using a Slasher.
- A copy of safety instructions must be kept in good condition with the Slasher.
- Generally, the safety instructions should be the manufacturer's instructions. Any variations from the manufacturer's instructions must be based on a risk assessment and must not remove any of the safety features nor expose anyone to risks.

Supervision, Instruction and Training

The employer must provide safe systems of work, adequate supervision, instruction and training to all those involved in using a Slasher. They must be instructed in the safe operation of the Slasher, including hazards specific to the workplace, including the terrain, stability of the tractor, working environment and the like. The employer should ensure that everyone achieves a level of understanding that enables them to safely and competently operate the Slasher.

Inspection, Maintenance and Repair

- The Slasher must be inspected according to the manufacturer's instructions, prior to use. See page 20 for Maintenance Instructions.
- All problems identified must be rectified, prior to use.
- The Slasher must be maintained according to the manufacturer's instructions.
- Replacement parts must be to the original manufacturer's specifications or their equivalent.
- Safety signs and decals should be legible, maintained and where necessary replaced.
- Repairs should be carried out by a competent person.
- When suspending the Slasher for maintenance or repair, whether attached to the tractor or suspended in another way, adequate safety stands must be used to prevent inadvertent lowering of the Slasher.

Service and Maintenance Safety

- Stop engine, set brake, remove ignition key and wait for all moving parts to stop before servicing, adjusting, repairing or unplugging.
- Support the equipment with blocks or safety stands before working beneath it.
- Follow good shop practices including:
 - keep service area clean and dry
 - be sure electrical outlets and tools are properly grounded
 - use adequate light for the job.
- Use only tools, jacks and hoists of sufficient capacity for the job.
- Replace and secure all shields removed during servicing before operating.
- Use heavy leather gloves to handle sharp objects.

SAFETY continued

Start-up Safety

- Do not let inexperienced operators or children use this equipment.
- Place all tractor and machine controls in neutral before starting.
- Operate only with Roll Over Protective System (ROPS) and seat belt equipped tractors.
- Do not operate inside a building unless there is adequate ventilation.
- Ensure all shields are in place and in good condition before operating.
- Stay clear of PTO shaft and machine when engaging PTO.

Operation

Prior to use, the Slasher should be inspected to ensure it is working correctly. All safety features must be included in this inspection. If any safety feature is not working correctly, the Slasher must not be used. The Slasher must be operated according to the manufacturer's instructions.

The operator must ensure that no-one is exposed to risks arising from the slashing operation.

Additional safety controls may be required when operating in the vicinity of people or traffic – e.g. alongside highways, roads or other public areas.

Where adjustable or removable guarding is provided for specific applications, such as vineyards and horticulture, and the guarding has been removed or is no longer effective, appropriate control measures must be implemented. These controls must ensure that the risk of injury is eliminated or controlled. Before using a Slasher in an application other than that outlined above, the guards must be readjusted or replaced so as to be effective.

Operation Safety

- Do not permit riders.
- Do not wear loose fitting clothing during operation.
- Never operate over 540 PTO rpm speed.
- Never operate the equipment in the raised position.

Personal Protective Equipment (PPE)

Prior to use, a risk assessment must be undertaken to determine the appropriate PPE required. Any identified PPE must be provided by the employer and must be used by those involved in the operation and maintenance of the Slasher. Examples of PPE are appropriate footwear and hearing & eye protection.

Storage and Transport

When not in use, the Slasher must be transported and stored according to the manufacturer's instructions. Requirements may differ when transporting a Slasher within a property and on a public road – you must comply with all statutory requirements.

Storage Safety

- Store the unit in an area away from human activity.
- Do not permit children to play on or around the stored machine.
- Support the frame on stands and blocks to provide a secure base.

Transport Safety

- Review Transport Safety instructions in tractor manual before moving.
- Check with local authorities regarding transport on public roads. Obey all applicable laws and regulations.
- Make sure the SMV (Slow Moving Vehicle) emblem and all the lights and reflectors that are required by the local highway and transport authorities are in place, are clean, and can be seen clearly by all overtaking and oncoming traffic.
- Never have the equipment in operation during transport.
- Always travel at a safe speed.

SAFETY continued

Modifications

A Slasher should not be modified or altered. However, if it is necessary to make modifications, they must be done by a competent person and based on a risk assessment. All modifications must comply with this industry safety standard.

Before any modifications are done, contact the manufacturer or supplier.

Anyone who undertakes modifications subsequently assumes the role and responsibilities of the designer and manufacturer. This does not include shortening a PTO shaft and cover when first installing the Slasher on a tractor (refer to page 10 for details).

The instructions relating to the Slasher and its use may need to be revised following a modification.

Any modifications made without manufacturers approval will void Warranty.

Safety Signs

- Refer pages 17-19 for the approximate location and detail of safety signs.
- Keep all safety signs clean and legible and replace any that are damaged or missing.
- When original parts are replaced, any safety signs affixed to those parts should be replaced as well. Replacement safety signs are available from your local dealer.

Installation of Safety Signs

- To install safety signs, ensure the installation area is clean and dry. Decide on the exact position before you remove the backing paper. Remove the smallest portion of the split backing paper and align over the specified area. Carefully press in place.
- Slowly peel back the remaining paper and smooth the remaining portion in place. Small air pockets can be pierced with a pin and smoothed out.

ASSEMBLY INSTRUCTIONS

STEP 1

Take all the components out from the packing crate and place the Slasher deck on a flat and level surface.

FIGURE 1

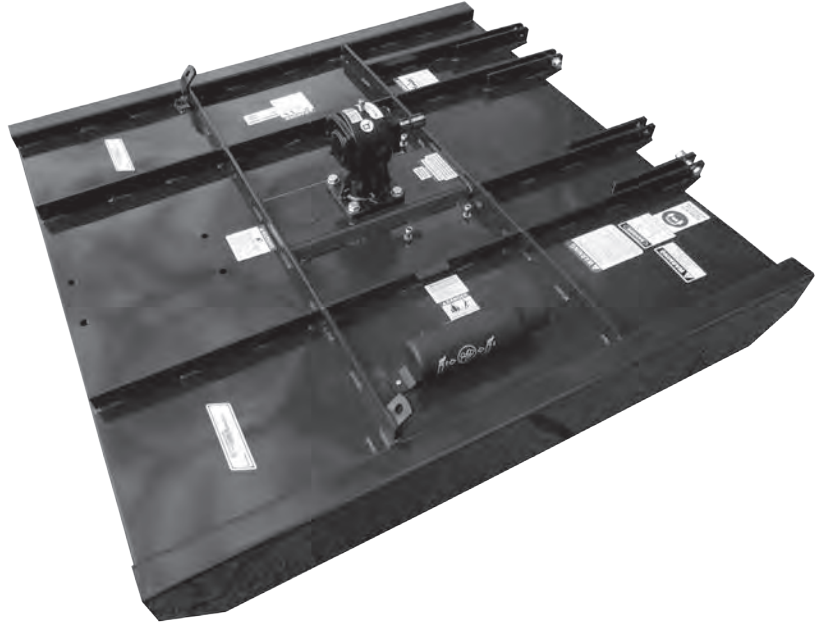

STEP 2

Inspect each component – lift arm frame (A), drag chain (B), bell shaped plastic safety guard (C), intake (D) and discharge (E) assemblies, slip clutch (F) and skid plates (G). Make sure there is no damage to the parts.

FIGURE 2



ASSEMBLY INSTRUCTIONS continued

STEP 3

First, install the plastic safety guard (AS8209) for 45HP gearboxes and (AS8409) for 75HP gearboxes using the four supplied – M8 x 12 Grade 8.8 bolts, flat and spring washers. Tighten the bolts to securely attach the safety guard to the gearbox as shown in Figure 5. Remove the side access panel from the safety guard using the two red plastic screws.

Second, install the slip clutch to the gearbox input shaft by sliding onto the six spline shaft. After the clutch has been slid onto the gearbox input shaft then secure the clutch by using the two – M12 x 75 Grade 8.8 bolts, nuts, spring washers and supplied retainer plate (refer Figure 6). Please insert bolts into retainer plate as shown in Figure 7. After bolts have been inserted please ensure the clutch is secured onto shaft passing through the locking groove on the gearbox input shaft (Figure 4). Tighten nuts. Please note that the heads of the retainer bolt will not turn as the retainer plate prevents the heads of the bolts from turning. Replace the side access panel to the plastic safety guard using the two red plastic screws.



FIGURE 3



FIGURE 4

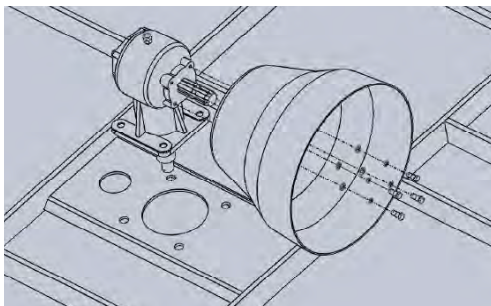

FIGURE 5



FIGURE 6



FIGURE 7

STEP 4

Mount the front / intake safety guard (Figure 2-D) to the Slasher using the four M10 x 30 Grade 8.8 bolts, flat and spring washers and nylock nuts. Tighten to securely fasten safety guard to Slasher.

Mount the rear / discharge safety guard (Figure 2-E) to the Slasher using the four M10 x 30 Grade 8.8 bolts, flat and spring washers and nylock nuts. Tighten to securely fasten safety guard to Slasher.

Check to see that the U-bolts used to secure the chains and wire rope to the Slasher are tight.

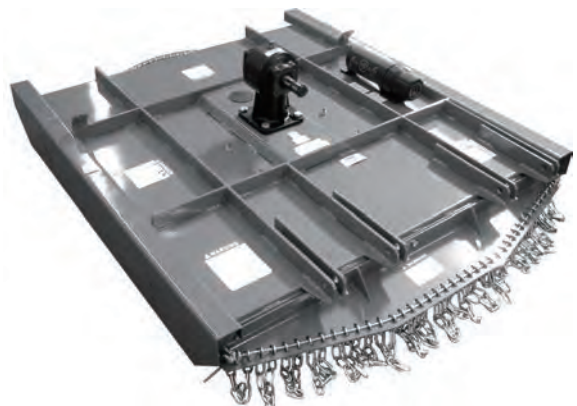

FIGURE 8

ASSEMBLY INSTRUCTIONS continued

STEP 5

Install the lift arm (A-Frame) to the Slasher deck as shown below using the provided M16 x 70 Grade 8.8 bolts. Tighten using the flat and spring washers and nylock nuts.

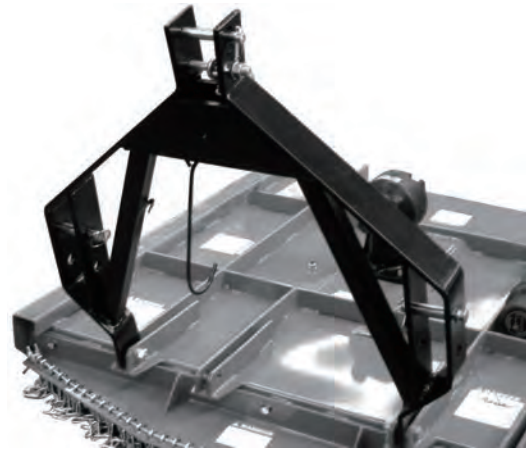

FIGURE 9

STEP 6

Attach the drag chain to the A – frame and the Slasher deck using four shackles. Important note: Chains and shackles supplied with all Southern Cross Ag Machinery Slashers are rated and **MUST NOT** be modified. If either shackles or chains require replacement please contact your local dealer or Southern Cross Ag Machinery for specifications.

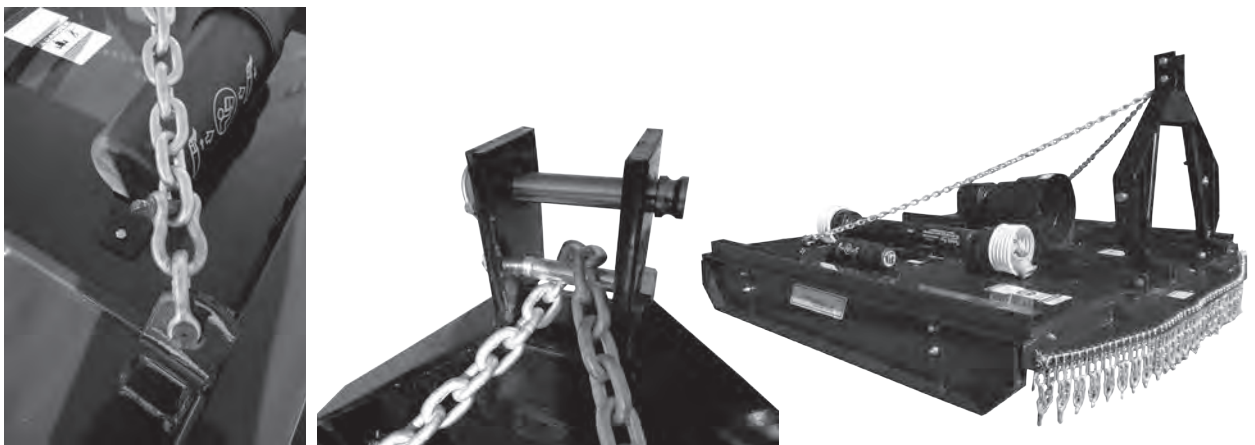

FIGURE 10

STEP 7

Use your tractor or other lifting device, with a rating suitable to raise the Slasher approximately 250mm above ground. Ensure the underneath of the Slasher body is properly supported by stands or blocks with the approved weight capacity. Make sure the Slasher is stable to ensure safety and **DO NOT INSTALL PTO DRIVELINE UNTIL THE ASSEMBLY IS COMPLETED.**

Install the two skid plates to the right side and the left side of the deck. Using eight M12 x 35 Grade 8.8 mounting bolts and eight flat washers and eight lock washers and eight hex nuts M12. Tighten the bolts and the nuts.

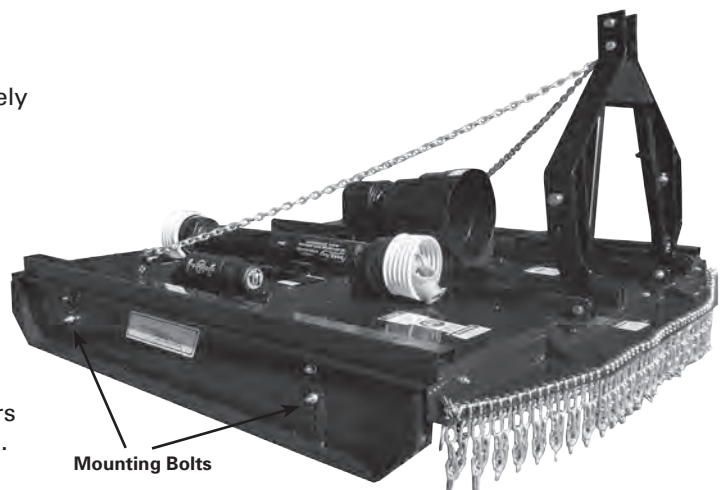

FIGURE 11

ASSEMBLY INSTRUCTIONS continued

STEP 8 – PTO SHAFT FIRST FITTING

If tractor and Slasher have never been used together before, please follow the instructions below:

- a. Separate the inner and outer halves of the drive shaft.
- b. Attach the tractor end of the drive shaft to the tractor PTO output shaft and the Slasher half to the gearbox input shaft or slip clutch.
- c. With the Slasher in the operating position hold the shaft halves parallel to each other to check that the two sections of the drive shaft do not close completely nor extend to a point less than one third of the sliding section.
- d. Repeat Step (c) with Slasher in fully raised position.



WARNING!

Refer to *Maintenance Safety* (pg. 16) regarding working on or maintaining a Slasher when raised using the tractor three point linkage.

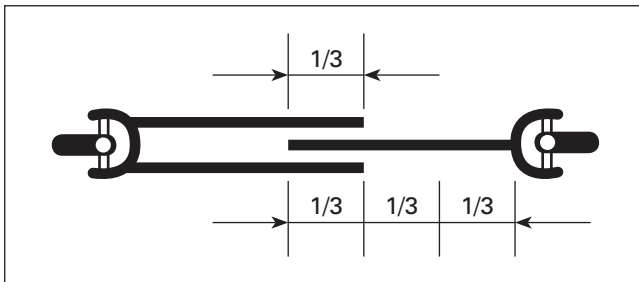

The diagram featured left shows the minimum engaged length for tri-lobal and 4-tooth style PTO shafts.

Note: Drawing unguarded schematic only. Never use a PTO shaft without approved safety guarding.

- e. If the PTO shaft is determined to be too long, cut equal amounts from both inner and outer half shafts and safety guards using a drop-saw or hacksaw. Remove any residual burrs or fillings from cutting and apply grease to both inner and outer shafts.
- f. If the PTO shaft is less than one third of the length of the engaged sliding section, please contact your dealer, as it may be necessary to replace with a longer drive shaft.

PRIOR TO OPERATION

BEFORE PUTTING Slasher INTO SERVICE IMPORTANT INSTRUCTIONS PRIORTO OPERATING MUST BE FOLLOWED.

SLASHER SHIPPED WITHOUT OIL IN GEAR BOX AND WITHOUT GREASE IN GREASE FITTINGS. UNIT MUST BE SERVICED BEFORE USING.

Fill Gearbox using Multipurpose Gear Oil (85/140). For all Grease Fittings use a high-temp / multipurpose grease.

STEP 1

Place Slasher so that the deck is secure and level.

STEP 2

Remove the breather plug located at top of gearbox and plug / grub screw (located on the side or rear of the lower half of gearbox).

STEP 3

Fill gearbox using multipurpose gear oil through top fill hole until gear oil is level with lower hole.

STEP 4

Replace both the breather plug (located at top of gear box) and plug / grub screw (located at lower 1/2 of gearbox) and clean off any excess oil.

STEP 5

Grease the following points:

*Both Universal Joints and Safety Guard grease points on the PTO Shaft.

STEP 6

Inspect all guards to insure they are in good working order and properly secured. If not replace before using.

STEP 7

Check all bolts and nuts to insure they are tight and secure.

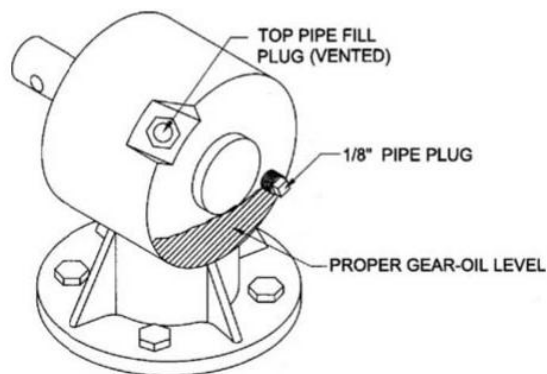

CAUTION

DO NOT overfill gearbox. This could cause damage to oil seals and can cause permanent damage to the gearbox. Any defects or failures caused by overfilling will not be covered under warranty

PREPARATION



Never operate the tractor and Slasher until you have read and completely understand this manual, the Tractor Operator's Manual and each of the messages found on the safety decals on the tractor and Slasher.

Personal protection equipment including hard hat, safety glasses, safety shoes, hearing protection and gloves are recommended during assembly, installation, operation, adjustment, maintenance, repairing, removal, or moving the implement. Do not wear loose fitting clothing or jewellery and be sure to contain long hair around equipment.

PROLONGED EXPOSURE TO LOUD NOISE MAY CAUSE PERMANENT HEARING LOSS! Tractors with or without Slashers attached can often create enough noise to cause permanent hearing loss. We recommend that you use hearing protection at all times. Long-term exposure to noise levels over 80db can cause severe hearing loss.

NOTE: Hearing loss from loud noises (from tractors, chain-saws, radios, and other sources close to the ear) is cumulative over a lifetime, with no chance of natural recovery.

Always wear your seat belt. Serious injury or even death could result from falling off the tractor particularly during a rollover when the operator could be trapped under the ROPS or the tractor.

Clear area to be cut of stones, branches and other debris that might be thrown causing injury or damage.

Operate only in daylight.

Do not operate Slasher in dry conditions as there is a risk of starting fires.

Ensure Slasher is properly mounted, adjusted and in good operating condition.

Ensure that all safety guards and safety decals are properly installed and in good condition.

STARTING AND STOPPING SAFETY



Check the tractor master guard over the PTO shaft. Make sure it is in good condition and fastened securely to the tractor. Purchase a new guard if old guard is damaged or missing.

All tractors that are not equipped with a "live" Power Take Off (PTO) need to be equipped with an over-running PTO clutch. These are available through most farm machinery dealers.

NOTE: The addition of an over-running PTO clutch may change the length of the PTO driveline required. Pay extra attention to the instructions on the PTO driveline installation refer page 10. Be sure that the driveline system guarding is sufficient.

Slasher operating power is supplied from the tractor PTO. Refer to your tractor manual for PTO engagement and disengagement instructions. Know how to stop the tractor and Slasher quickly in case of an emergency.

The engine RPM should always be at idle speed when engaging the PTO. Once engaged and you are ready to start cutting, increase the PTO speed to approximately 540RPM and maintain throughout the cutting operation.

The use of this equipment is susceptible to certain hazards that cannot be protected against by mechanical means or product design. All operators of this equipment must read and understand this entire manual, paying particular attention to safety and operating instructions, prior to using.

Most accidents occur because of neglect or carelessness. Keep all assistants and bystanders one hundred metres from the operating Slasher. When machine is operated in populated areas where thrown objects could injure persons or property, operation must be stopped if anyone comes within one hundred metres.

The Slasher is designed for the use on tractors with 540-RPM power take off.

STARTING AND STOPPING SAFETY *continued*



Install and secure all guards and shields before starting or operating. The discharge chute, flaps, chains, driveline guards and tractor guards should be used and maintained in good working condition. They should be inspected carefully daily for missing or broken cables, chain links, shields and guards. Worn items must be replaced at once to reduce the possibility of injury.

Disengage Power Take Off (PTO) and place tractor transmission in neutral before attempting to start engine.

Many varied objects, such as wire, cable, rope or chains can become entangled in the working parts of the Slasher. These objects could then swing outside the housing at a greater velocity than the blades. Such an occurrence is extremely hazardous. Inspect the cutting area for such objects before slashing. Remove any objects from the site.

Never allow the cutting blade to contact objects. Cut higher first, allowing Slasher to clear such hidden objects. Never assume an area is clear. Always check!

Always stop the tractor, disengage PTO, allow cutter blades to come to a complete stop, lower implement to the ground, set park brake, shut off the tractor engine and remove the ignition key before dismounting tractor. Never leave equipment unattended while the tractor is running.

Never place hands or feet under Slasher. Stay clear of all moving parts.

Do not reach or place any part of your body under the equipment until it is blocked securely.

Do not allow riders on the Slasher or tractor at any time. There is no safe place for riders.

Do not operate unless all personnel, livestock and pets are at least one hundred metres away to prevent injury by thrown objects. Never direct the discharge chute towards anyone.

Never operate tractor and Slasher under trees with low hanging limbs. Operators can be knocked off the tractor and then be run over by the Slasher.

The rotating parts of this machine have been designed and tested for rugged use. However, they could fail upon impact with heavy, solid objects such as steel, concrete, rocks or stumps. To reduce the possibility of property damage, serious injury or even death never allow the cutting blades to come in contact with such objects.

Stop Slasher and tractor immediately upon striking an obstruction. Turn engine off, remove key, engage park brake then inspect and repair any damage before resuming operation.

Stay alert for uneven terrain, holes, roots and other hidden hazards. Keep away from drop-offs and hazards that could cause roll-over. Use extreme caution and maintain minimum ground speed when transporting or operating on hillsides, over rough ground and when operating close to ditches or fences. Be careful and slow down when turning sharp corners and changing direction on slopes. Do not start or stop suddenly on slopes and avoid operating on steep slopes. In extremely uneven terrain, rear wheel weights, front tractor weights and / or tire ballast should be used to improve stability.

Drive Slasher diagonally over sharp dips and avoid sharp drops to prevent tractor and Slasher from "hanging up". Always cut downward on slopes, never cut across the face. Always check tractor manual for proper use on slopes. Practice will improve your skills in manoeuvring on rough terrain.

TRANSPORT SAFETY



Always observe state and local laws governing highway safety and the travel of farm machinery on public roads.

When driving the tractor and equipment on roads or highways use flashing amber warning lights and a slow moving vehicle (SMV) identification emblem. Do not exceed 20kph. Reduce speed on rough roads and surfaces.

Plan your route to avoid heavy traffic.

Always install transport locks, pins or brackets before transporting.

Do not drink and drive.

Be a safe and courteous driver. Always yield to oncoming traffic in all circumstances, including narrow bridges, intersections etc. Watch for traffic when crossing or operating in close proximity to roadways.

Use extreme care and maintain minimum ground speed when operating close to ditches and or fences. Be careful when turning sharp corners.

Never allow riders on either tractor or Slasher.

ATTACHING TO TRACTOR



WARNING

Never stand between tractor and Slasher while backing the tractor up to the hitch



STEP 1

Attach to tractor's three point hitch as described in the Tractor's Operator's Manual.

STEP 2

Apply any multipurpose grease to the outside of the male (inner) PTO shaft section.
Assemble PTO shaft and install on Slasher and tractor.

STEP 3

Pull shaft on the tractor side of the PTO shaft yoke to be sure it has locked in place. Make certain PTO shaft guards are in place and good working condition. Repeat this same process for the PTO shaft connection to the Slasher.



WARNING

Failure to install the retaining clip or quick coupler on the gearbox input shaft would allow the driveline to swing freely causing possible injury or death.



OPERATING INSTRUCTIONS

This Slasher was designed to CUT PASTURE GRASS AND ROUGH AREAS UPTO 1" IN DIAMETER. Use of your Slasher to cut any material larger than 1" in diameter may damage the Slasher and void warranty.

PREOPERATIONAL ADJUSTMENTS

Set tractor's lift control stop at a position that will prevent the PTO shaft from coming in contact with the front edge of the Slasher when it is at full lift. Consult your tractor manual for instructions.

MAINTENANCE SAFETY



Good maintenance is your responsibility.

- Follow good shop practices
- Keep service area clean and dry.
- Be sure electrical outlets and tools are properly grounded.
- Use adequate light for the job at hand.

Make sure there is ample ventilation. Never operate tractor engine in a closed building. The exhaust fumes may cause asphyxiation.

Before working on this machine, disengage the PTO, be certain all moving parts on attachments have come to a complete stop, shut off engine, set the park brakes and remove the ignition keys before attempting to perform maintenance.

Do not perform maintenance or work on the Slasher on uneven or sloping surfaces.

Never work under equipment unless Slasher is properly supported by blocks or stands under the body with appropriate approved weight capacity.

Always use personal protection devices such as eye, hand and hearing protectors when performing any service or maintenance.

Frequently tighten all bolts, nuts, screws and check to make certain unit is safe to operate.

When completing maintenance or service, make sure all safety guards and devices are installed before using the Slasher.

After servicing, be sure all tools, parts and service equipment are removed from the Slasher.

Do not allow debris, grease or oil to build up on any part of the deck or platform.

Where replacement parts are necessary for periodic maintenance and servicing, factory replacement parts must be used to restore your equipment to original specifications. Contact your local dealer or Southern Cross Ag Machinery regarding supply or replacement parts.

The manufacturer and / or distributor will not be responsible for injuries or damages caused by the use of unapproved parts and or accessories.

A first aid kit should be kept readily accessible while performing maintenance on this equipment.

STORAGE SAFETY



Following use, or when unhooking the Slasher, disengage the PTO, stop the tractor, set the park brakes, shut off the engine and remove the ignition keys.

Store the unit in an area away from human activity.

Do not park equipment where it can be exposed to direct contact with livestock for long periods of time. Damage to Slasher and or livestock could result. Make sure all parked machines are on a hard, level surface and that all safety devices are engaged.

SAFETY DECAL LOCATIONS

The safety decals and their positions are shown on the illustration below. Good safety requires that you familiarize yourself with the various safety decals, the type of warning and the area or specific function related to that area that requires your SAFETY AWARENESS.

REAR / DISCHARGE

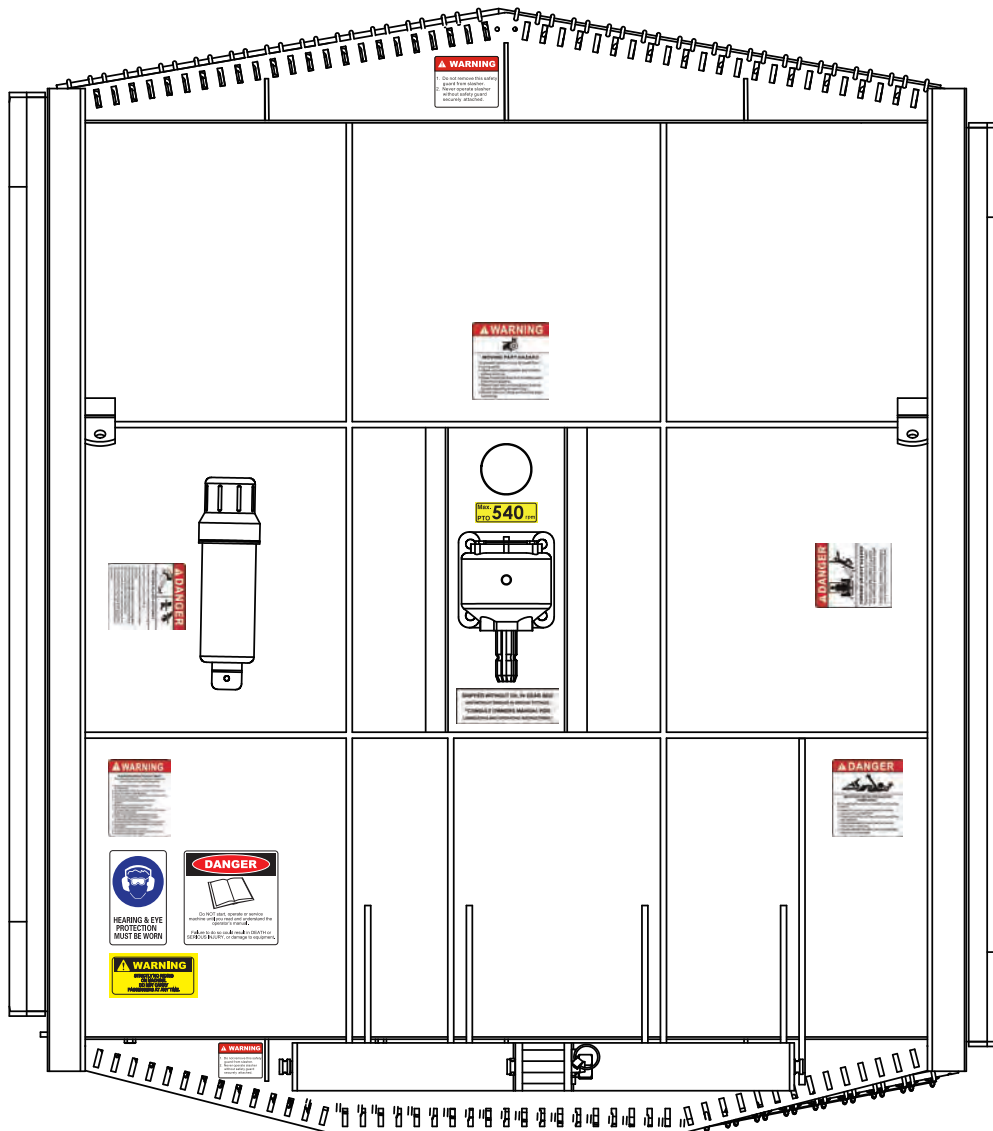

FRONT / INTAKE

REMEMBER: If the safety decals have been removed or damaged new safety decals must be applied. Please contact Southern Cross Ag Machinery or your local dealer if you require new decals.

⚠ WARNING



MOVING PART HAZARD

To prevent serious injury or death from moving parts:

- Close and secure guards and shields before starting.
- Keep hand, feet, hair and clothing away from moving parts.
- Disconnect and lockout power source before adjusting or servicing.
- Do not stand or climb on machine when operating.

1

⚠ WARNING

To prevent serious injury or death:
Si no lee inglés, pide ayuda a alguien que sí lo lee para que le traduzca las medidas de seguridad

- Read and understand Operator's Manual before using. Review annually.
- Do not permit riders on the tractor or mower, including children.
- Do not allow children to operate mower.
- Operate only with guards installed and in good working condition.
- Keep away from moving parts.
- Operate only with tractor equipped with ROPS and seatbelts.
- Before mowing, clear debris from mowing area.
- DO not operate in the raised position.
- Stop engine, lower mower, set brake and wait for all moving parts to stop before dismounting.
- Support mower securely before working beneath unit.
- Transport with clean reflectors, SMV and working lights as required by federal, state, and local laws.
- Keep yourself, others, and clothing away from the rotating POT.
- Keep other away from area to be mowed to avoid injury from flying objects.
- Do not stand between tractor and mower.
- Be careful on uneven terrain. Decrease speed when turning.
- Do not exceed a safe transport speed.

2

⚠ DANGER



**ROTATING DRIVELINE HAZARD
KEEP AWAY**

To prevent serious injury or death from rotating driveline:

- Keep all guards in place when operating.
- Operate only at 540 RPM
- Keep hands, feet, clothing and hair away from moving parts.
- Do not operate without driveline securely attached at both ends.
- Do not operate without driveline shields that turn freely on driveline.

3

⚠ DANGER



THROWN OBJECT HAZARD

To prevent serious injury or death:

- Do not operate unless all guards are installed and in good condition.
- Stop blade rotation if bystanders come within several hundred feet.

4

⚠ DANGER



ROTATING BLADES-KEEP AWAY

To prevent serious injury or death when the engine is running and the blades are rotating:

- Never allow riders, especially children, on tractor or mower.
- Do not operate with bystanders in mowing area.
- Do not operate with deflector/guards removed.
- Do not place hands or feet under deck.
- Do not stand on or near implement at any time.
- Do not stand between tractor and implements.
- Operate only with tractor equipped ROPS and seatbelts.

5

**SHIPPED WITHOUT OIL IN GEAR BOX
AND WITHOUT GREASE IN GREASE FITTINGS.
"CONSULT OWNERS MANUAL FOR
LUBRICATING AND OPERATING INSTRUCTIONS."**

SLASHER SAFETY DECALS continued



7



8



9



10



11

MAINTENANCE SCHEDULE

Southern Cross Mowers recommends that the following routine service / maintenance schedule be followed to ensure the efficient and safe operation of your Slasher. If followed this maintenance schedule will maximise the working life of the Slasher.

PRIOR TO FIRST USE OF SLASHER

1. Check all bolts and nuts are tightened correctly
2. Check all hitch pins are securely locked
3. Check Bow Shackles on drag chains are tight
4. Ensure Quick Coupler Pins on the PTO shaft are secured correctly to both the Slip Clutch (Slasher end) and to the tractor PTO output shaft
5. Ensure slip clutch is set correctly
6. Check gearbox oil level. Add oil if required
7. Check PTO shaft has been greased as per instructions listed on bottom of this page.

AFTER FIRST THREE HOURS OF OPERATION

1. Check all bolts and nuts are tightened correctly
2. Check gearbox oil level. Add oil if required

AFTER EVERY EIGHT HOURS OF OPERATION

1. Grease PTO shaft as per instructions listed on bottom of this page.
2. Check Cutter Beam for any signs of damage and check Retaining Nut to gearbox is tight and split pin is still in place
3. Check blades for signs of damage or excessive wear. Replace if necessary
4. Ensure blade retaining plough bolts and self locking nuts are not damaged and are tight
5. Check Clutch settings and make adjustments if necessary
6. Check for any debris from cutting or items such as wire are not built up around gearbox output shaft and cutter beam
7. Clean Slasher deck and remove any cuttings or other debris that has built up on the Slasher. In heavy slashing conditions cuttings may need to be cleared from the deck more frequently.

AFTER EVERY 40 HOURS OF OPERATION

1. Complete all processes as per eight hour service
2. Check all bolts and nuts are tightened correctly
3. Check all hitch pins are securely locked
4. Check Bow Shackles on drag chains are tight
5. Check PTO shaft universal joints for any signs of wear. Replace any worn components if required.

PTO SHAFT MAINTENANCE

PTO shaft universal joints and telescopic sections should be greased with a good quality high temperature grease similar to (MP) Multipurpose Chassis Grease every 20 hours for average conditions. In severe operating conditions grease should be added every eight hours.

Safety guard bearings should be lubricated by applying general purpose grease to the plastic grease nipples on the bell guards every 20 hours.

REPLACING BLADES

It is recommended that whenever blades require replacing on a Southern Cross Ag Machinery Slasher the following components also be replaced. Blade retainer bolts, nylock nuts, washers and hardened wearing collars bolts must be tightened to 350 ft. /lb. These are listed in the Parts List on pages 26-27 of this Manual. Specifications are also detailed and must be replaced using genuine Southern Cross Ag Machinery parts. Please contact your local dealer or Southern Cross Ag Machinery for any parts required.

TROUBLE SHOOTING GUIDE

PROBLEM	POSSIBLE CAUSE	POSSIBLE REMEDY
Leaves a streak of uncut or partially cut grass	1. Slasher not level side to side	Level 3pt. hitch linkage on tractor
	2. Blades dull or bent	Sharpen or replace blades
	3. Carrier speed too low	Use correct PTO speed
	4. Field conditions are so wet that the tractor tyre is pushing grass into mud.	Too wet to slash. Stop operation and wait for drier conditions
	5. Ground speed too fast	Reduce ground speed by shifting to a lower gear
	6. Blades lock back	Free blades
	7. Blades riding up due to blade bolt wear.	Replace blade bolts and hardened bushes'
	8. Grass is laying down from previous weather conditions.	Slash in only one direction
	9. Possible build up of material under Slasher	Clean Slasher
	10. Weed and grass stems are pushed down by the tractor tyres and do not rebound up so they can be cut	Slash back and forth with enough overlap to slash tyre track of previous cut again
Grass cut lower in centre swath than at edge	Height of Slasher lower at rear of front.	Adjust Slasher height and attitude so that Slasher rear and front are within 1/2" of same height
Gearbox overheating	1. Low on lubricant	Fill to proper level
	2. Improper type of lubricant	Replace with proper lubricant
	3. Excessive debris build-up	Remove debris around gearbox
Blade is scalping ground	1. Slasher too low	Raise Slasher and 3pt. control stop
	2. Field is too ridged	Cut field at a different angle
	3. Field is too wet	Stop and wait until it is drier
Slasher will not cut all the time	Slip clutch is slipping	Adjust slip clutch according to instructions
Slasher moves from side to side when cutting	Loose tractor sway chains, bars or sway blocks improperly installed	Adjust sway chains, bars or sway blocks
PTO contacts Slasher front frame when raised	Raising Slasher too high or incorrect adjustment of tractor top link	Adjust top link or tractor lift stops
Blade bolts come loose	1. Bolts not tightened	Tighten bolts to 350 ft. /lb
	2. Bolt hole elongated or oversized	Replace blade carrier
	3. Blade bolt threads are worn or damaged.	Replace blade bolt, washer, nylock nut and hardened bush
Blade wears too fast	1. Cutting in sandy conditions	Increase cutting height
	2. Cutting in rocky conditions	Increase cutting height
	3. Blades hitting ground	Increase cutting height

TROUBLE SHOOTING GUIDE continued

PROBLEM	POSSIBLE CAUSE	POSSIBLE REMEDY
Slasher seems to require excessive power	1. Advancing into grass or bush too rapidly	Reduce forward travel speed
	2. Hitting ground	Raise Slasher
	3. Worn or dull blades	Replace blades
	4. Tractor not large enough	Use higher horsepower tractor
Excessive vibration	1. Check gearbox bolts	Tighten if loose
	2. Check for loose nuts on all components	Tighten if loose
	3. Check for bent output Shaft, oil will normally leak from bottom seal	Replace shaft if bent
	4. Check to see if blades are free-swinging	Free blades so they swing
	5. Check for even wear on each blade tip. Were both blades changed at the same time?	Weigh blades. Weight should be within 30 grams. Always replace both blades.
	6. Blade broken	Replace blades in sets
	7. Blade beam bent or damaged	Replace blade beam
	8. New blade or bolts matched with worn blade or bolts.	Replace blades and bolts in sets
	9. Drivelines not phased correctly implement and tractor yokes must be in line.	Replace driveline
	10. Wire or rope wrapped around blade beam.	Remove wire or rope
	11. Blades worn and are out of balance.	Replace blades in sets
Gearbox Noisy	1. Rough gears	Run in or change gears
	2. Worn bearings	Replace bearing
	3. Low oil in gearbox	Check level and add oil.
Gearbox leaking (continued on following page)	1. Damaged oil seal	Replace seal
	2. Bent shaft	Replace oil seal and shaft
	3. Shaft rough on oil seal area	Replace or repair shaft
	4. Oil seal installed incorrectly	Replace seal and install correctly

TROUBLE SHOOTING GUIDE continued

PROBLEM	POSSIBLE CAUSE	POSSIBLE REMEDY
Gearbox leaking (continued)	5. Oil seal not sealing in the housing	Replace seal or use a sealant on outside diameter of seal
	6. Oil level too high	Drain oil to proper level
	7. Hole in gearbox	Replace gearbox
	8. Gasket damaged	Replace gasket
	9. Bolts loose	Tighten bolts
Front hitch "A" frame bending sideways	1. Operator turning sharply hitting objects with tail wheel frame or Slasher deck	Drive carefully and plan turns to avoid hitting buildings, posts, trees etc.
	2. Slasher is being operated too low and Slasher is contacting ground during turns.	A. Raise Slasher (especially on rough ground) B. Set stop on hitch controls lever so hitch lift arms do not drop Slasher on ground.
	3. Tractor 3pt. hitch leaking / creeping down and Slasher deck is contacting ground	A. Repair tractor hitch hydraulic system B. Use limit chains to keep arms from going lower than set limit.



FOR FURTHER INFORMATION

WorkCover NSW

Visit www.workcover.nsw.gov.au

Call the WorkCover Assistance Service on **13 10 50**

Call the WorkCover Publications Hotline on **1300 799 003**

Visit your nearest WorkCover office.

For technical specifications on Slashers, contact your local manufacturer.

SafeWork South Australia

GPO Box 465

Adelaide SA 5001

Help Centre: **1300 365 255**

Website: www.safework.sa.gov.au

Workplace Health and Safety Queensland, Department of Justice and Attorney-General

GPO Box 69

Brisbane QLD 4001

Workplace health and safety infoline: **1300 369 915**

Electrical Safety infoline: **1300 650 622**

Website: www.worksafe.qld.gov.au

WorkSafe Victoria

Advisory Service 222

Exhibition Street

Melbourne VIC 3000

Telephone: **03 9641 1444**

Toll free: **1800 136 089**

Email: info@worksafe.vic.gov.au

Website: www.worksafe.vic.gov.au

WorkSafe Western Australia

1260 Hay Street

West Perth WA 6005

Telephone: **08 9327 8777**

Toll Free: **1300 307 877**

Email: safety@commerce.wa.gov.au

Website: www.worksafe.wa.gov.au

SLASHER PARTS DIAGRAM

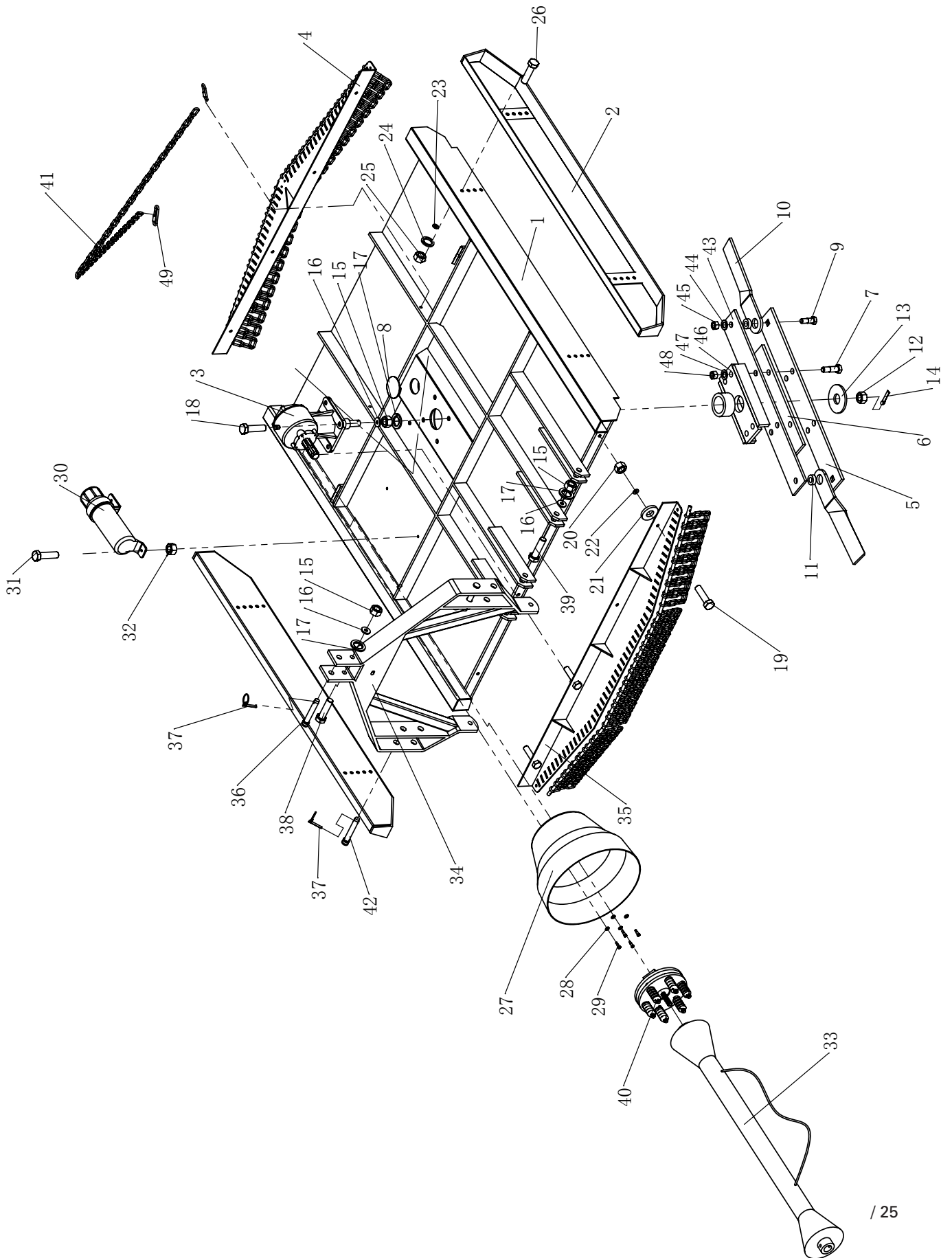

SLASHER PARTS LIST

PARTS NUMBER	DESCRIPTION	QUANTITY
1	Main Body	1
2	Skid Plate	2
3	Gear Box	1
4	Rear Chain Guard	1
5	Cutter-Bar Bottom Plate	1
6	Cutter-Bar Middle Plate	1
7	Hex Bolt M20x80 (Grade 8.8)	4
8	Rubber Cap	1
9	Plow Bolt 3/4" x 2 3/4" (Grade 9)	2
10	Cutting Blade (B6002)	2
11	Blade Bush (B7468)	2
12	Castle Nut M28	1
13	Flat Washer 30	1
14	Cotter Pin Ø 5	1
15	Hex Nut M16	7
16	Lock Washer M16	7
17	Flat Washer M16	7
18	Hex Bolt M16x45 (Grade 8.8)	4
19	Hex Bolt M10x30 (Grade 8.8)	7
20	Hex Nut M10	11
21	Lock Washer M10	11
22	Flat Washer M10	11
23	Flat Washer M12	8
24	Lock Washer M12	8
25	Hex Nut M12	8
26	Hex Bolt M12x35 (Grade 8.8)	8
27	Slip Clutch Safety Guard	1
28	Flat Washer M8	4
29	Hex Bolt M8x12 (Grade 8.8)	4
30	Manual Holder	1
31	Hex Bolt M8x20	2
32	Lock Nut M8	2
33	PTO Driveline	1
34	Lift Arm	1
35	Front Chain Guard	1
36	Center Hitch Pin Ø 19	1
37	Lynch Pin	3

SLASHER PARTS LIST continued

PARTS NUMBER	DESCRIPTION	QUANTITY
38	Hex Bolt M16×120 (Grade 8.8)	1
39	Hex Bolt M16×70 (Grade 8.8)	2
40	Slip Clutch	1
41	Drag Chain Grade 70	1
42	Side Hitch Pin Ø 22 Grade 70	2
43	Cutter Bar-Top Plate	1
44	Flat Washer 3/4" (Grade 8.8)	2
45	Lock Nut 3/4" (Grade 8.8)	2
46	Blade Carrier Boss and Block	1
47	Flat Washer 20	4
48	Lock Nut M20	4
49	Bow Shackles B2060 or KSBG08C Grade-S	4



WARRANTY

Southern Cross Ag Machinery warrants all their products against defective workmanship and, or materials for a period of twelve (12) months from the date of purchase. A three-year extended warranty program applies to gearboxes supplied with the following products; Slashers, finishing mowers and post-hole diggers sold from June 25th 2009. For attachments used in commercial enterprises the Warranty period is six (6) months on all components with the exception of components that are not included as per the detailed listed in the next paragraph. Proof of purchase plus proof of the defect will be required and must be received by Southern Cross Ag Machinery within seven days of product failure and prior to the end of the twelve (12) month period from date of purchase. A *Warranty Claim Form* MUST be lodged through the Dealer where the item was purchased. A *Warranty Claim Number* will be issued. Work commenced without a Claim Number issued and therefore warranty approval will not be covered by Southern Cross Ag Machinery.

Southern Cross Ag Machinery takes no responsibility for the repair of any products rendered defective or damaged through normal wear and tear or incorrect use of the product. Southern Cross Ag Machinery does not provide warranty on any cutting blades, tilling / hoe blades, rippers, scarifiers, tynes, tyres, clutch plates, friction plates, V-belts and Post Hole Digger cutting bits. Southern Cross Ag Machinery does not provide warranty on any products that have undergone modification. Southern Cross Ag Machinery reserves the right to determine whether the product is defective. Southern Cross Ag Machinery does not accept responsibility for any product which is damaged in transit. Faulty parts may need to be returned to Southern Cross Ag Machinery as part of the Warranty process. Freight costs each way will be paid by the owner / purchaser of the product.

Purchasers, dealers or agents of the Southern Cross Ag Machinery product are not authorised to give warranty on behalf of Southern Cross Ag Machinery. Claims will only be recognised, if lodged as outlined on page 29 in the *Warranty Process*. Any work commenced without Southern Cross Ag Machinery approval will not be honoured.

Product specifications are subject to change due to our company's policy of improvement. Design changes and improvements maybe made by Southern Cross Ag Machinery whenever it believes the effectiveness of its products can be improved. Southern Cross Ag Machinery has no obligation to incorporate any improvements to products, which are currently in service or have been supplied.

REGISTER YOUR WARRANTY

To register your Warranty please ensure the dealer from where the product has been purchased completes the *Southern Cross Ag Machinery Installation / Warranty Registration* Form. This triplet document needs to be signed by the purchaser. One copy remains with the Dealer, one copy needs to be mailed to Southern Cross Ag Machinery (PO Box 454, Rutherford NSW 2320) and one copy will remain with the purchaser for your reference.

If you have any queries regarding the warranty of your Southern Cross Ag Machinery product please call our office Tel. (02) 4932 3011 or email sales@sxm.com.au.



WARRANTY PROCESS

1. Contact your dealer or point of purchase who will contact Southern Cross Ag Machinery.
2. Photos and or video footage may be required to process your claim with a short description of the problem. This will be lodged through your dealer or point of purchase by the completion of the Southern Cross Ag Machinery *Warranty Claim Form*.
3. The claim will be assessed by Southern Cross Ag Machinery to determine whether the warranty claim will be approved. This can take up to five working days from when Southern Cross Ag Machinery is first notified of the problem and proof of product failure along with *Warranty Claim Form* is supplied.
4. If the *Warranty Claim* is approved a *Warranty Claim Number* will be issued to the Dealer.
5. Any work commenced without approval from Southern Cross Ag Machinery and without a *Warranty Claim Number* will not be covered by Warranty. Repairs must be made by Southern Cross Ag Machinery or an authorised dealer. Southern Cross Ag Machinery reserves the exclusive right to determine whether it will pay labour costs for warranty repairs or replacements and the amount of such costs that it will pay and the time in which the repairs will be made. Southern Cross Ag Machinery will not approve invoices sent for repairs that Southern Cross Ag Machinery has not previously approved.
6. Travel and freight charges associated with the processing of the Warranty Claim will not be covered by the Southern Cross Ag Machinery Warranty and is the responsibility of the owner / purchaser.

DISCLAIMER

Whilst information is true at time of printing actual product may differ slightly from the product described herein due to our company's policy of improvement. Errors and omissions may happen from time to time, we apologise for any inconvenience should this occur. Products may differ slightly in appearance to illustrations / photographs provided.

SOUTHERN CROSS AG MACHINERY
1/29 MUSTANG DRIVE, RUTHERFORD NSW 2320
PO BOX 454. RUTHERFORD NSW 2320

T. 02 4932 3011

WWW.SXM.COM.AU

AUTHORISED SXM DEALER

